

186 ES-S

► Description

Exposed, Sensor Activated Royal® Model Urinal Flushometer, for ¾" top spud urinals.

► Flush Cycle

- Model 186-1.0 ES-S Low Consumption (1.0 gpf/3.8 Lpf)
- Model 186 ES-S Water Saver (1.5 gpf/5.7 Lpf)

► Specifications

Quiet, Exposed, Diaphragm Type, Chrome Plated Urinal Flushometer with the following features:

- PERMEX™ Synthetic Rubber Diaphragm with Dual Filtered Fixed Bypass
- OPTIMA® EL-1500 Self-Adaptive Infrared Sensor with Indicator Light
- Non-Hold-Open Integral Solenoid Operator
- Die Cast Sensor Cover Plate with no visible Fasteners (for 2-gang Electrical Box)
- 1" I.P.S. Screwdriver Bak-Chek® Angle Stop
- Free Spinning Vandal Resistant Stop Cap
- Adjustable Tailpiece
- High Back Pressure Vacuum Breaker Flush Connection with One-Piece Bottom Hex Coupling Nut, Spud Coupling and Flange for ¾" Top Spud
- Sweat Solder Adapter w/Cover Tube and Cast Wall Flange w/Set Screw
- High Copper, Low Zinc Brass Castings for Dezincification Resistance
- Non-Hold-Open Integral Solenoid Operator, Fixed Metering Bypass and No External Volume Adjustment to Ensure Water Conservation
- Flush Accuracy Controlled by CID™ Technology
- Diaphragm, Stop Seat and Vacuum Breaker molded from PERMEX™ Rubber Compound for Chloramine Resistance

Valve Body, Cover, Tailpiece and Control Stop in conformance with ASTM Alloy Classification for Semi-Red Brass. Valve in compliance with the applicable sections of ASSE 1037. Installation conforms to ADA requirements.

► Accessories

- EL-154** Transformer (120 VAC/24 VAC 50 VA)
- EL-342** Transformer (240 VAC/24 VAC 50 VA)
- EL-518-A** Flushometer Electrical Box Positioning and Support Kit

See Accessories Section and OPTIMA Accessories Section of the Sloan catalog for details on these and other OPTIMA Flushometer variations.

► Fixtures

Consult Sloan for Sloan brand matching fixture options.

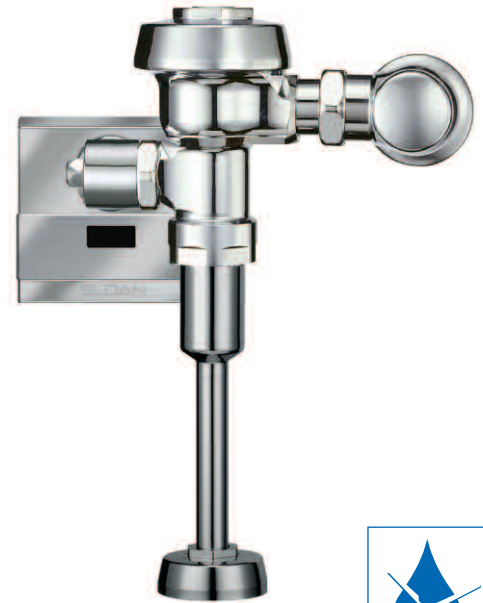

► Automatic

Sloan OPTIMA® equipped Flushometers provide the ultimate in sanitary protection and automatic operation. There are no handles to trip or buttons to push. The Flushometer operates by means of an infrared sensor that adapts to its surrounding. Once the user enters the sensor's effective range and then steps away, the Flushometer Solenoid initiates the flushing cycle to flush the fixture.

► Hygienic

User makes no physical contact with the Flushometer surface. Helps control the spread of infectious diseases. 24-Hour Sentinel Flush keeps fixture fresh during periods of nonuse.

► Economical

Automatic operation provides water usage savings over other flushing devices. Reduces maintenance and operation costs.

► Practical

Solid state electronic circuitry assures years of dependable, trouble-free operation. The operational components of the Flushometer are identical to a handle activated Royal® Flushometer, proven by 90 years of experience.

► Warranty

3 year (limited)

Sloan Electronics are:



Made In The
USA

186 ES-S

Description

Exposed, Sensor Activated Royal® Model Urinal Flushometer, for 3/4" top spud urinals.

Flush Cycle

- Model 186-1.0 ES-S Low Consumption (1.0 gpf/3.8 Lpf)
- Model 186 ES-S Water Saver (1.5 gpf/5.7 Lpf)

ELECTRICAL SPECIFICATIONS

Control Circuit

- Solid State
- 24 VAC Input
- 24 VAC Output
- 8 Second Arming Delay
- 24-Hour Sentinel Flush

OPTIMA Sensor Range

- Nominal 15" - 30" (381 mm - 762 mm)
- Self-adaptive Window ± 8" (203 mm)

Solenoid Operator

24 VAC, 50/60 Hz

Transformer

Sloan Part #EL-154
120 VAC, 50/60 Hz Primary
24 VAC, 50/60 Hz Secondary
Class II, UL Listed, 50 VA.

Sloan Part #EL-342
240 VAC, 50/60 Hz Primary
24 VAC, 50/60 Hz Secondary
Class II, UL Listed, 50 VA.

WIRING DIAGRAM

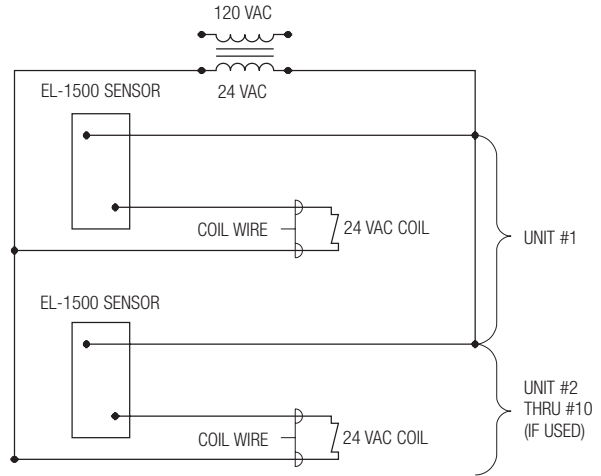

One Transformer serves up to ten (10) OPTIMA Closet/Urinal Flushometers. Specify number of transformers required accordingly.

OPERATION

1. A continuous, invisible light beam is emitted from the OPTIMA Sensor.

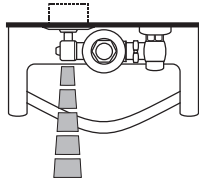

2. As the user enters the beam's effective range (15" to 30") the beam is reflected into the OPTIMA Scanner Window and transformed into a low voltage electrical circuit. Once activated, the Output Circuit continues in a "hold" mode for as long as the user remains within the effective range of the Sensor.

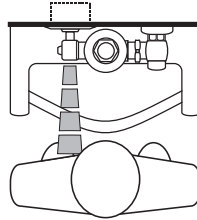

3. When the user steps away from the OPTIMA Sensor, the circuit immediately initiates an electrical "one-time" signal that operates the Solenoid. This initiates the flushing cycle to flush the fixture. The Circuit then automatically resets and is ready for the next user.

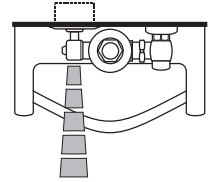

ROUGH-IN

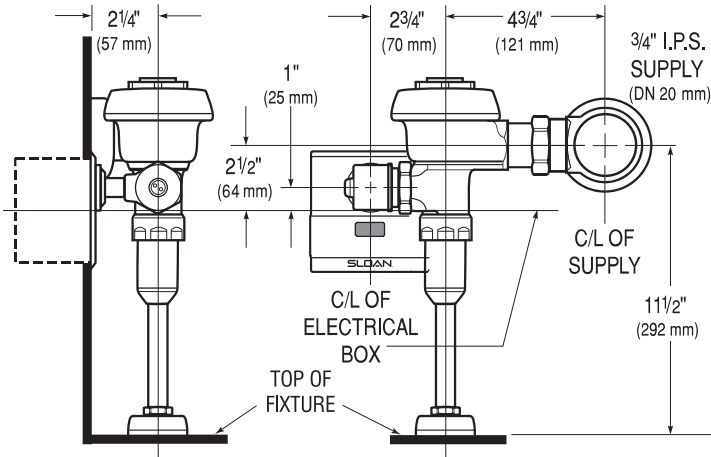

To ensure a perfect rough-in, Sloan recommends the use of the EL-518-A Flushometer Electrical Box Positioning and Support Kit. Specify and order the EL-518-A Kit separately. Consult factory for installation details.

ELECTRICAL BOX INSTALLATION

SENSOR LOCATION AND POSITIONING IS CRITICAL

Failure to properly position the electrical boxes to the plumbing rough-in will result in improper installation and impair product performance. All tradesmen (plumbers, electricians, tile setters, etc.) involved with the installation of this product must coordinate their work to assure proper product installation. Installation Template furnished with Flushometer.

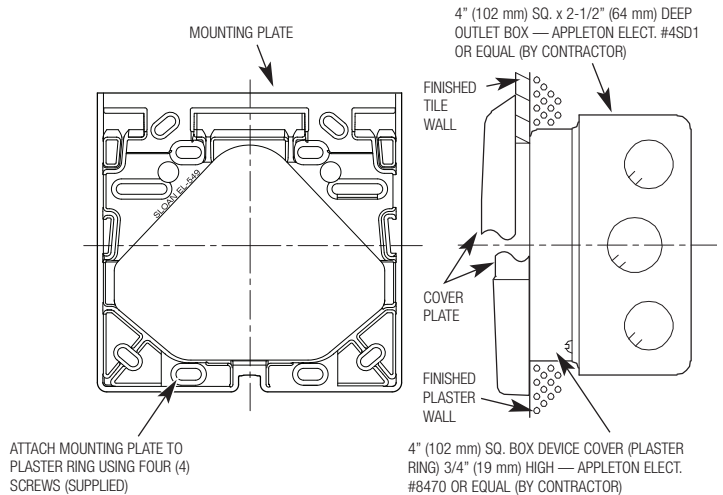

TouchFree Concepts

29965 N. 78th Place, Scottsdale AZ 85266

(800)908-1098

www.touchfreeconcepts.com